

# Application to Pursue Social Distancing Virtually using Smart Queue Management System

Ms. Aakanksha Shashank Chavan  
aakankshachavan4@gmail.com  
*Computer Engineering*  
(MCOERC, Nashik)  
NASHIK, MAHARASHTRA

Ms. Prachi Kishor Patil  
prachipatil0199@gmail.com  
*Computer Engineering*  
(MCOERC, NASHIK)  
NASHIK, MAHARASHTRA

Ms. Vaishali Vijay Tambe  
vaishalitambe234@gmail.com  
*Computer Engineering*  
(MCOERC, NASHIK)  
NASHIK, MAHARASHTRA

Mr. Dhananjay Balasaheb Tayade  
dannytayade1495@gmail.com  
*Computer Engineering*  
(MCOERC, NASHIK)  
NASHIK, MAHARASHTRA

Dr. Swati A. Bhavsar  
bhavsar.swati4@gmail.com  
*Computer Department*  
(MCOERC, NASHIK)  
NASHIK, MAHARASHTRA

**Abstract**—Management of high loads at sales and service-oriented stores presented a significant challenge in streamlining service delivery during the global corona pandemic that struck the world in 2020. Consumers primarily needed to maintain social distancing at all the stores to purchase even the basic commodities such as grocery, healthcare products, self-care products, etc. People also struggled to avail essential services such as hospitalization, education, housing, transport, etc. Even after observing all the precautionary measures at all public locations, it was seen that maintaining social distancing proved to be a huge task which leads to the uncontrolled spread of the virus. Smart Queue Management System (SQMS) presents a viable solution for crowd management in such scenarios. However, conventional QMS are not generic by design, depend on component environment or do not provide a comprehensive end-to-end solution that caters to the complete consumer workflow. This project presents a mobile-augmented smart queue management system that can be easily configured with an operational Store-Customer Integration System. It provides multiple interfaces for slot booking and consumption on mobile devices integrated with store information, while using smart systems for queue generation and allocation. The solution is comprehensive as that it caters to streamlined queue management, in stores that can be categorized across several service areas, using customer-friendly interface, which improves customer experience and also helps the store administration track and optimize key performance metrics. We present the architectural and operational design of this system, along with an illustration of the use of this system in improving the healthcare precautions across the globe.

**Index Terms**—social distancing, crowd management, mobile augmented, slot booking, queue generation

## I. INTRODUCTION

As we have been witnessing the brutal spread of the global pandemic of COVID-19 corona virus, it has specifically become the need of the hour to ensure the safety of people by observing social distancing protocols in public service areas, such as government offices, shops, malls, stores and other

service-based premises.

A queue management system is used to streamline customer flow through businesses such as banks, hospitals and government offices that get large crowds of people during working hours. Instead of making them all crowd around counters for service, the queue system will ensure safe distancing.

This app proposes a smart queue management system for delivering real-time service request updates to clients' smartphones in the form of visual feedback. The proposed system aims at reducing the dissatisfaction with services with medium to long waiting times. The proposed system also improves the waiting experience of clients by connecting them to queue management, and participating client units in the form of smartphone applications.

An SQMS allows customers to join the line from anywhere, at any time, using smartphones. They can join the queue using a simple request sent from their phone, or by booking an appointment on the app. They can queue up using a mobile app, or even through social media.

The system is designed to avoid contact between people in crowded places such as malls, hospitals, banks, government offices, shops. This app is used for social distancing and is user friendly. In this system the user is supposed to register itself on the application and once logged in they can browse locality near itself through the dashboard of the application through proposed system, user can book a slot in the current queue of a particular store which is managed by the store manager/worker. This system allows user to be in safe environment and helps maintain social distancing rules, this helps to save time and effort of both customer and store. The user has to register itself on application and can use social media account for the same. The store user has to register itself on the web application. After registration they can create and manage the queue and the working time of the store. The created queue can be deleted updated and the size of queue can be set by

the owner of the store.

## II. PROPOSED SYSTEM

This proposed system is based on the combination of a mobile application that runs on android platform with the minimum version of Android 5.0, which is dedicated for the consumer user, and a web application that is dedicated for the store user. The mobile application consists of the interface between the consumer profile and the store profiles.

The consumer registers himself on the application using his credentials or else using his social media account. The consumer, after successfully registering on the application, has to login to his profile. After logging in, the consumer lands on the dashboard page where he can see various options to browse his profile or to search for a store on the basis of various sorting options. The consumer user has the option to search stores 'near him', in which case the location of the consumer's mobile device is accessed and the stores are displayed in ascending order of the distance from the user. The consumer may apply filters such as 'less than x kms', 'open now', '0 waiting', and 'rating'. The other option for browsing the stores is using a search option that displays stores from a specific locality of the consumer's choice. Once the stores are displayed, the user can see whether the store is open or closed, and if open, it shows the number of consumers in the two queues, i.e., the 'serving' and 'waiting' queues, and also the distance between the consumer and that store is displayed. The consumer can book a slot in the store of his choice and can start navigation till the store. Once the consumer arrives at the store, he may verify his queue at the entrance and get served for the slot. After the payment of his bill, the consumer exits the store and his queue slot is killed by the store user.

Unlike the consumer user, the store user registers on the web application using the store credentials. After successful registration, the store user lands on the dashboard page where they see various options to browse their profile, and set up the queues and working time for the store. The store has to setup their profile by including the store location so that any user may search and navigate to the store. While setting up the queues, the store has the option to set the queue size independently for both the serving and waiting queue. Once the queue strength has been set, the store has to declare the opening and closing time for the store. Whenever a queue is booked for a store, the store has to verify the queue on the customer's arrival. Once the customer has consumed their slot the store has the right to kill the customers slot after the bill payment. Only after the slot has been killed, it will reflect so in the waiting or serving queue.

## III. SYSTEM ARCHITECTURE

The Figure 1 resembles the overall architecture of the proposed system. Both, the web software and the mobile application are connected through the master database. Both the platforms deal in Smart Queue Management System and set or access the queues as per the rights assigned to the respective platforms. Through the web software, the store

user defines the queue sizes, whereas through the mobile application, the consumer user accesses the queues predefined by the stores, and book a queue accordingly.

The master database is the first-step landing for the web software user as well as for the mobile application user. The master database interacts with the dynamic database and the static database. Whenever a new user, either a store or a consumer, registers on the platform, their profile data and login credentials are stored in the static database, as there is minimal possibility that the data would change or update. The static database would hold data such as the store/consumer's name, store/consumer phone number, store/consumer email address, store/consumer profile picture, store/consumer address, and any other required data. The dynamic database holds the queue related data, such as the queue sizes and the availability details. These are some elements that have a higher possibility of being altered or updated more often, and as they might keep dynamically changing; hence they are stored in the dynamic database.

As discussed in the introduction, the store has to define their location and the user needs to navigate to the store location. For handling these location and navigation related tasks, the system comprises of a 'Global Positioning System' application programming interface (API) that provides map features. Also, the user verification process involves email verification task, and to handle the same 'email verification' application programming interface (API) has been included in the system. The GPS API and the email verification API are involved in both, the web software (store user) and the mobile application (consumer user).

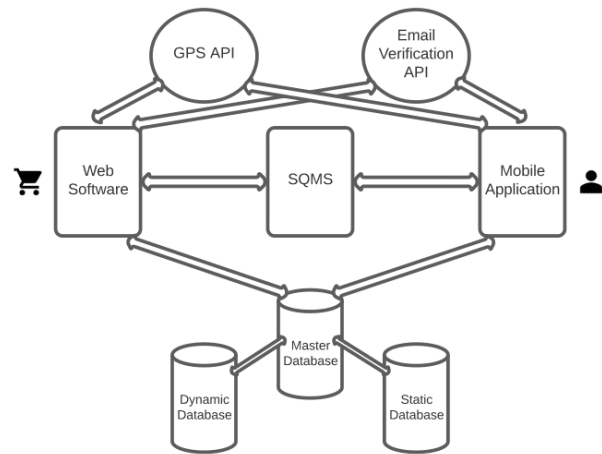

Figure 1: System architecture

The Figure 2 describes the interaction between the mobile application (consumer user) and the real-time cloud database. There is a 'request and acknowledgement' process carried out repeatedly between the application and the database. There are a few interactions instances that take place during this process. Instance 1: First time logging in and refreshing dashboard; in this, the mobile application sends a request to the database

to fetch the login details or profile details for a particular user, and once fetched, they are stored in cache for further references. The database then gives the user access to the metadata and lets them fetch the respective details for the action being performed. Instance 2: First time opening a page or refreshing a page; in this, the mobile application sends a request to the database to fetch the for a particular page that the user wants to view, and once fetched, they are stored in cache for further references. The mobile application can even send an update request when they wish to refresh the page they are viewing. The database then gives the user access to the metadata and lets them fetch or update the respective details for the action being performed. Instance 3: queue operations; in this, the mobile application sends a request to the database to fetch the queue status of a certain store and perform CRUD (create, update, delete) operations on the same. In response, the database updates and keeps track of the queue metadata according to the operations performed by the user.

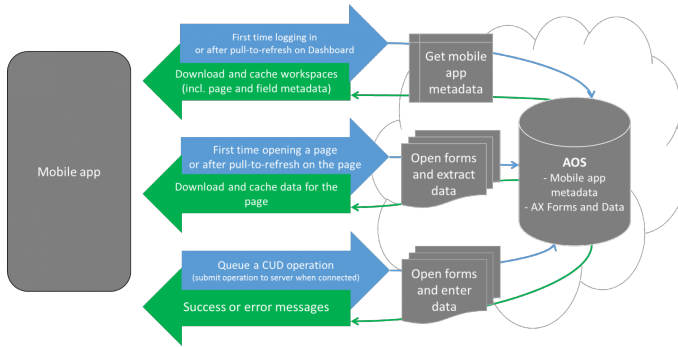

Figure 2: Mobile application - Realtime Database Interface

#### IV. SEQUENCE DIAGRAM

The Sequence Diagram highlights the working of the token generation for the 'book queue/slot' function that is offered for the consumer in the mobile application. The classes and functions within them are mentioned and described using the figure.

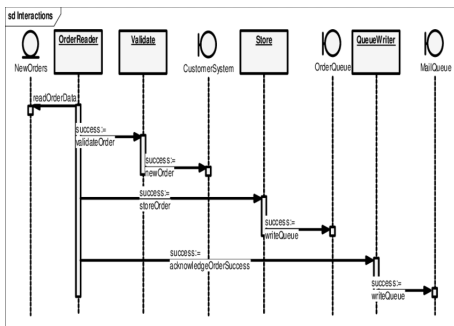

Figure 3: Sequence diagram

In this, the NewOrder class will create a new order for token generation. Then the OrderReader function will read the order and will send the order for validation. When the order is successfully validated. Then the store will hold the validated order and wait for receiving acknowledgement from

the OrderReader when it receives it. It will send the successful order to QueueWriter and the QueueWriter function will write the order to MailQueue and the MailQueue will generate the new order that is new queue.

#### V. LIMITATIONS

Even though this proposed system projects systematic features that enables the users to book and utilize slots in various service-based premises, it still has a few limitations that arise during the handling and management of the queues. Now we will discuss such limitations in this section.

When a user fails to utilize the booked queue slot, it cannot be determined whether the user will be showing up in the given slot time. Although, this system has been induced with a fail-safe procedure, where in case if the user fails to utilize the queue slot, when active, within a certain time-frame specified by the store, then the slot for that user will be terminated automatically by the system. Whereas, the users who are next-in-line for being served after the user who have failed to show up, have to wait until the slot is terminated by the system.

In case the user, whose slot has been terminated automatically by the system after the wait-time, shows up, there is no provision made in the system to handle such scenario and adjust the slot for that user in the serving queue. Such user has to book a queue slot again and get in the back of the serving or waiting queue as per the current queue availability. As the queue slot termination right belongs with the store user, in case if the store's web software handler misses or fails to terminate the queue slot of a customer even after the slot being utilized, there is no provision made in the system to tackle such scenario. In this case, the non-terminated slot remains in the queue and blocks the next-in-line users from getting the access to their slot and thus have to keep waiting until the queue slot is terminated.

The consumer has to verify their entry in the store to make their queue slot active. If in case a user fails to verify his entry, then his queue slot would not be activated leading to the situation where even the store could not terminate the slot as it has not been activated in the first place, and hence would be auto-terminated by the system after the completion of the wait-time. Again, in such cases, the next-in-line users have to wait until the slot is terminated.

These limitations could be addressed and removed in the future work and development of the system.

#### VI. LITERATURE SURVEY

Vasumathi.A,Dhanavanthan P formulated a suitable simulation technique which will reduce idle time of servers and waiting time of customers. Dr. Ahmed S. A. AL-Jumaily, Dr. Huda K. T. AL-Jobori have presented a new technique for queuing system called automatic queuing system. The proposed technique showed improvements in average waiting time. Mrs. S.Maragatha Sundari, Dr. S.Srinivasan have used the highly suitable modeling tool for MMC queuing model, the stochastic Birth-death Markov process and have eliminated the long waiting hours for customers. S. Vijay Prasad and V.

H. Badshah recommends changing the present queuing system to alternate queuing system where the passengers do not need to wait so long. It was proved that this model of the queuing system is feasible and the results are effective and practical. Aizan et al. present a “walk-away” queue management system where the conventional token dispensers and token calling hardware at counters are replaced by Android devices and a service-based model for generation and management of tokens is presented.

#### FUTURE WORK

[1] Add Contact Tracing - In this, for future work we can enhance the app base code for contact tracing between people or with someone who has been tested and whose status is verified as covid-19 positive. This will help the user to get tested and prevent the condition.

[2] Testing Status - We can in future add testing status of user such that he/she will know when user last tested for covid-19. This data can be compared to a history of other users that were not social distanced so that the user can gain the information for their personal risk.

[3] Self-Assessment - The app can also be used for self-assessment. The app will show the status of yourself assessment for yourself and also the last date of it along with self-assessment guidelines.

[4] QR Generator - While visiting pharmacies, parks, salons, malls, petrol pumps, public transport Users can get real-time data on how crowded a particular area is. Although, this can only work if all stores and public places will have a QR generator. Users will need to scan the QR code each time they visit a place .Another thing we can do in this app is user has to enter their address then they will be able to see the amount of people which are in that particular location.

[5] Distancing Clock - The App base code could be enhanced to clock Start day, Current day, End Day Restart clock if newly exposure.

[6] Track My Activity - Users can get a daily, weekly or fortnightly report of their social distancing practices. The app also provides 24x7 emergency helpline, family trip tracking option, roadside assistance service, ambulance services, among others. It has a “Track My Trip” feature that tracks the activity of the user between two places marked in the app.

#### CONCLUSION

This paper discusses all the merits and demerits of the existing QMSs. This paper presented a mobile-augmented smart QMS that can be used for end-to-end customer management at stores. The developed system provides interfaces on mobiles, desktops for store and customer portals. It has smart queue generation algorithms for streamlining customer experience and load at store service counters. It allows the customer to be in safe environment following the rules of social distancing and also it leads to save the time and effort of both the customer and store.

#### REFERENCES

- [1] Sumit Soman, Sudeep Rai, Priyesh Ranjan, Amarjeet Singh Cheema and Praveen K Srivastava, “Mobile-Augmented Smart Queue Management System for Hospitals”, 2020.
- [2] S. Keerthana, K. Mekala and V. Vaneeswari, “Smart Queue Management System for Banking Sector”, 2020
- [3] C. C. Batbagon, O. B. Jayme Jr, and J. P. Pradilla, “I-queue: A centralized queue management system,” 1 st Semester of 2018, p. 24, 2018.
- [4] K. Hedau, N. Dhakare, S. Bhongle, S. Hedau, V. Gadigone, and N. Titarmare, “Patient queue management system,” 2018.
- [5] R. Sahney, “Smart opd framework–new era in the digital healthcare initiative of sir ganga ram hospital,” Current Medicine Research and Practice, vol. 6, no. 5, pp. 204–207, 2016.